



Main

Range of product	Harmony XALD
Product or component type	Complete control station
Device short name	XALD
Product destination	For XB5 Ø 22 mm control and signalling units
Control station application	Start-Stop function
Colour of base of enclosure	Light grey RAL 7035
Colour of cover	Dark grey RAL 7016
Material	Polycarbonate
Operator profile	2 flush push-buttons
Operators description	Green "START" 1 NO - red "STOP" 1 NC
Control station composition	1 flush push-button green 1 NO START marking 1 flush push-button red 1 NC STOP marking
Marking location	Marking on legend holder
Contact operation	Slow-break

Complementary

Cable entry	2 knock-outs for cable entry, clamping capacity: 14 mm 2 knock-outs for Pg 13 cable gland and ISO M20, clamping capacity: 12 mm
Product weight	0.233 kg
Resistance to high pressure washer	7000000 Pa at 55 °C, distance: 0.1 m
Positive opening	With conforming to EN/IEC 60947-5-1 appendix K
Operating travel	1.5 mm (NC changing electrical state) 2.6 mm (NO changing electrical state) 4.3 mm (total travel)
Operating force	3.5 N (NC changing electrical state) 3.8 N (NO changing electrical state)
Mechanical durability	10000000 cycles
Connections - terminals	Screw clamp terminals : ≤ 2 x 1.5 mm ² with cable end conforming to EN/IEC 60947-1 Screw clamp terminals : ≥ 1 x 0.22 mm ² without cable end conforming to EN/IEC 60947-1
Tightening torque	0.8...1.2 N.m conforming to EN/IEC 60947-1
Shape of screw head	Cross, Philips no 1 Cross, pozidriv No 1 Slotted, flat Ø 4 mm Slotted, flat Ø 5.5 mm

Contacts material	Silver alloy (Ag/Ni)
Short-circuit protection	10 A by gG cartridge fuse conforming to EN/IEC 60947-5-1
[I _{th}] conventional free air thermal current	10 A conforming to EN/IEC 60947-5-1
[U _i] rated insulation voltage	600 V (degree of pollution: 3) conforming to EN/IEC 60947-1
[U _{imp}] rated impulse withstand voltage	6 kV conforming to EN/IEC 60947-1
[I _e] rated operational current	AC-15, A600: U _e = 120 V I _e = 6 A conforming to EN/IEC 60947-5-1 AC-15, A600: U _e = 240 V I _e = 3 A conforming to EN/IEC 60947-5-1 AC-15, A600: U _e = 600 V I _e = 1.2 A conforming to EN/IEC 60947-5-1 DC-13, Q600: U _e = 125 V I _e = 0.55 A conforming to EN/IEC 60947-5-1 DC-13, Q600: U _e = 250 V I _e = 0.27 A conforming to EN/IEC 60947-5-1 DC-13, Q600: U _e = 600 V I _e = 0.1 A conforming to EN/IEC 60947-5-1
Electrical durability	1000000 cycles AC-15, 2 A at 230 V, operating rate: ≤ 3600 cyc/h, load factor: 0.5 conforming to EN/IEC 60947-5-1 appendix C 1000000 cycles AC-15, 3 A at 120 V, operating rate: ≤ 3600 cyc/h, load factor: 0.5 conforming to EN/IEC 60947-5-1 appendix C 1000000 cycles AC-15, 4 A at 24 V, operating rate: ≤ 3600 cyc/h, load factor: 0.5 conforming to EN/IEC 60947-5-1 appendix C 1000000 cycles DC-13, 0.2 A at 110 V, operating rate: ≤ 3600 cyc/h, load factor: 0.5 conforming to EN/IEC 60947-5-1 appendix C 1000000 cycles DC-13, 0.5 A at 24 V, operating rate: ≤ 3600 cyc/h, load factor: 0.5 conforming to EN/IEC 60947-5-1 appendix C
Electrical reliability	$\Lambda < 10\exp(-6)$ at 5 V, 1 mA conforming to EN/IEC 60947-5-4 $\Lambda < 10\exp(-8)$ at 17 V, 5 mA conforming to EN/IEC 60947-5-4

Environment

Protective treatment	TH
Ambient air temperature for storage	-40...70 °C
Ambient air temperature for operation	-40...70 °C
Overvoltage category	Class II conforming to IEC 60536
IP degree of protection	IP69 IP67 IP66 conforming to IEC 60529 IP69K
NEMA degree of protection	NEMA 13 NEMA 4X
IK degree of protection	IK03 conforming to EN 50102
Standards	EN/IEC 60947-1 EN/IEC 60947-5-1 EN/IEC 60947-5-4 EN/IEC 60947-5-5 JIS C 4520 UL 508 CSA C22.2 No 14
Vibration resistance	5 gn (12...500 Hz) conforming to IEC 60068-2-6
Shock resistance	30 gn (duration = 18 ms) for half sine wave acceleration conforming to IEC 60068-2-27 50 gn (duration = 11 ms) for half sine wave acceleration conforming to IEC 60068-2-27

Contractual warranty

Warranty period	18 months
-----------------	-----------

Dimensions

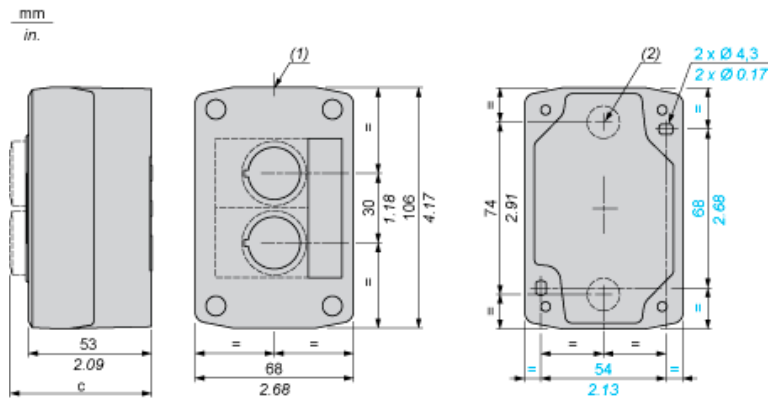

- (1) 2 knock-outs for Pg 13.5 cable gland, maximum capacity 12 mm/0.47 in.
 (2) Knock-out for cable entry, maximum capacity 14 mm/0.55 in.

Control station fitted with:	c in mm	c in in.
Flush pushbutton	62	2.44
Pilot light	64	2.52
Illuminated pushbutton	65.5	2.58
Projecting pushbutton	66	2.60
Selector switch	80	3.15
Mushroom head pushbutton	91.5	3.58
Latching mushroom head Emergency stop pushbutton with key	115	4.53
Key switch	105.5	4.15